

THE KINDRED OF GOD

BRO CHARLES OTIENO KONYANGO

CFM 31ST JULY 2022

GENESIS. 24:1-6, 37-38

50-0815 - WHO IS GOD?

18....Then He begin to create. And He made the fishes of the sea, the vegetable life. Put the cattles on the hill. It all looked good to Him.

Then He said, “Let us make man in Our own image, after Our likeness.” Is that right? All right. So He made a man. God was Spirit; he had to be a spirit man made in His image. He put him here on the earth to lead the animal life and so forth, like the Holy Spirit should be leading the Church today. That was man.

53-0729 - QUESTIONS AND ANSWERS ON GENESIS

17 But when God made His first man, if you noticed, He made him in the likeness of Himself, he was made in the image of God. And what is God? Now, if we can find out what God is, we can find what kind of a man He made.

53-0611 - SHOW US THE FATHER AND IT'LL SATISFY US

186 “Let Us make man in Our Own image;” and if He made a man in His Own image, He made a supernatural being. Yes, indeed. Genesis 1:28 read and see if that isn’t right. And then when He made man in His Own image, he had rule over the beasts. He led the beasts around then, like the Holy Spirit is supposed to lead the Church today. That’s right. He led the Church around and...

53-0729 - QUESTIONS AND ANSWERS ON GENESIS

20 Now, the next verse is where I want:

God is a Spirit: and they that worship him must worship him in spirit and in truth.

53-0729 - QUESTIONS AND ANSWERS ON GENESIS

21 Now, if God created man in His Own image and in His Own likeness, what kind of a man did He create? A spirit man. Now, if you'll notice, after He had made all the creation, and created a spirit man, the close reading of this now (to the one that asked the question) will find this, that God give dominion of the cattle and the fishes and everything to the man. But, in His making up there, He made man in His Own image to lead the cattle, lead the beasts of the field, just like the Holy Spirit leads the believer today. See?

63-1110M - SOULS THAT ARE IN PRISON NOW

38 And then, first, man was made, he was a spirit man, in the image of God.

39 Which, “God is a Spirit,” Saint John 4. Now, “He is a—a Spirit. And they that worship Him, worship Him in Spirit and in Truth. And Thy Word is the Truth.” Now, we worship Him in Spirit and Truth. He is a—a Spirit Being.

53-1122 - THE RESURRECTION OF LAZARUS

13 Man before he was this man, he was a spirit man. God made the first man in His Own image. How many says that's right? Well, what kind of a image has God got? He's a Spirit, is that right? So He made a Spirit man 'fore He made a flesh man.

53-1212 - THE INSIDE MAN

19 Would you...Do you ever think that inside of our body is another man? Did you know that, that there's another man inside of our body? And that's a spirit man. Did you ever think of that, Brother Ryan? To see what...Yes, sir. That how this in here, the inside man...

**HE CHOSE YOU IN HIM: HIS OWN IMAGE AND
LIKENESS**

55-0116A - THE BELIEVER'S POSITION IN CHRIST

35 That's the reason you're holy this afternoon, not because you deserve it, but because He chose you to be that way. When? Before the foundation of the world.

...holy and without blame before Him in love:

How could we do it? There had to be a Masterpiece do that, and that was Christ Jesus.

Listen, you don't remember it, neither do I; but we was before the foundation of the world.

When God made man said, “Let Us make man in our own image, let us give them (plural), let Us get...make man in our Own image (spirit man) and give them dominion over the fishes of the sea, and the cattle’s and so forth.” Genesis 1, God saying that, “Let Us make man.” ...

34 Now, quickly now, I'll give you my view, and then we'll have to go.

According as He has...as He...(God)...has chosen us...(Not my desire, not your desire, wasn't Paul's desire.)

But he has chosen us in Him before the foundation of the world...

Did you think of that? He chose us in him before the foundation of the world, that we...

...that we should be holy,...

Not cause I lived right, because He chose me to be that way. He done it, not I.

55-0116A - THE BELIEVER'S POSITION IN CHRIST

36 Now, back there before the foundation of the world, God chose you in Christ Jesus to appear holy at the end time, all the way from the foundation of the world. Do you see it?

Now, quickly, let's catch it now, next verse.

Having predestinated... (or elected) us unto the adoption of children by Christ Jesus to Himself, according to—to the good pleasure of His will,...

55-0116A - THE BELIEVER'S POSITION IN CHRIST

38 Now, look. He has chosen us for this purpose, having predestinated or foreknowledge, He fore-understood what it would be from the beginning. God in the beginning, knowing just what He would do at the end, He predestinated, or could foretell, what it would be: foreknowledge, foreknowing to be in Christ Jesus.

65-0829 - SATAN'S EDEN

50 Like, you are an attribute of your father. And, you notice, you was in your grandfather's grandfather's grandfather's. But, in that, say, we'll take it down to like you and your father. Now, you did not know anything when you were in your father.

The germ of life comes from the male. The male has the blood cell; the woman has the—the egg; now, therefore, the blood cell has the life in it. And, then, when you were in your father, you actually knowed nothing about it. But, yet, science and God's Word proves that you were in your father, but you knowed nothing about it.

65-0829 - SATAN'S EDEN

51 But then the father longed to know you. And with the union of connection with mother, then you were made known to father. Now, you are your father's attribute. You look like him, and you've got parts of your body that looks like your father.

65-0829 - SATAN'S EDEN

52 Now, that's the way God was in the beginning. Every son of God and every daughter of God was in God at the beginning. You don't remember it now, but you were there. He knowed it. And He wanted you to become so He could contact you, speak with you and love you, and shake your hands.

65-0829 - SATAN'S EDEN

54 And so God knew that we would be here, but then He put us in flesh so we would be contacted. In order He could contact, He become one of us when He become Jesus Christ, the Son of God Himself, the fullness of the manifestation of God. Therefore that was God's purpose, to display His attributes in fellowship.

65-0829 - SATAN'S EDEN

55 When I was in my father, I knew nothing about it. But when I become his son and was born of him, I was a attribute, a part of my father. And you're a part of your father.

MALE AND FEMALE CREATED HE THEM (GEN.1:27):
SO ADAM (THE GROOM) AND EVE (THE BRIDE)
WERE THE SAME THING

64-0402 - JEHOVAH-JIREH #1

118 What was Eve? Her and Adam were the same. They were called Adam. They were spirit. When He formed man, the first time, He made him in His Own image. And God is a Spirit. “In the image of God created He him, male and female created He them.” He was...and then still there was no man to till the soil. Then God formed man out of the dust of the earth and put this dual spirit into him, and that was the first Adam.

GENESIS 2:21-23

63-0728 - CHRIST IS THE MYSTERY OF GOD REVEALED

188 And to be sure, that, the whole Rapture now: Luther was a part, Wesley was a part, the prophets was a part. If they're—aren't a part...Just in the revelation that they was making up, the body, feet, toes, arms, and so forth, until the Head (which we get to that in a few minutes), see, that makes the entire Rapture. It's the Body of the Word, which is Christ. Amen!

63-0728 - CHRIST IS THE MYSTERY OF GOD REVEALED

189 Outside of That, you're lost. I don't care how good you are, or what your relationship is, or what your fellowship is, or what your organization is, you're lost, outside of that Word being in you.

64-0402 - JEHOVAH-JIREH #1

120 But in this case, to the Royal Seed, called, predestinated to Eternal Life, the Royal Seed of Abraham, they believe that Word. I don't care what comes or goes, how much they laugh, who says *this, that, or the other*, they are ordained to Eternal Life. And she goes right straight back. Her and her Lover, Christ, is one. The Life, the Spirit that's in Christ, is in the Church. That's their Eternal covenant, here. See?

God took the Spirit of Christ, tore it apart, at the sacrifice at Calvary; and took that Spirit, lifted up the body and set it on the right hand of the Throne of God and Majesty on High. That's, everything in Heaven is controlled by Him. And then the Spirit that was upon Him, come back; the same Spirit, not another Spirit, the same Spirit come upon Him, to confirm the covenant to the Royal Seed.

65-0418M - IT IS THE RISING OF THE SUN

241 The Spirit left Him, in the Garden of Gethsemane. He had to die, a man. Remember, friends, He didn't have to do that. That was God. God anointed that flesh, which was human flesh. And He didn't...If He'd a went up there, as God, He'd have never died that kind of death; can't kill God. But He didn't have to do it.

242 But, remember, He went there with you in Him. See, God had never separated the Bride from the Groom, yet. So when God looked down upon the body of Christ, He saw both male and female. It was all redeemed in that one body. See? They are one, same, same Word. The same Word, spoke of the Groom, speaks of the Bride.

243 Well, how can the Bride come, and fail to manifest everything was promised of Him; and the Groom come, and He wouldn't be the Bride? But when He did everything, even to proving it by raising Himself up from the dead, afterwards, then don't the—the Bride have to do the same thing, have to be exactly what the Word said She would be in these last days?

Don't She have to return through Malachi 4?
Don't She have to be manifested like it was in the
days of Sodom? Don't the world have to be just
exactly like it is? Isn't these things a perfect
identification of the Word of God made known to
us?

65-0418M - IT IS THE RISING OF THE SUN

245 Look, notice this. But God foresaw the Bride in the Groom. Hallelujah! See, to save His Wife, like Adam, He had to go with Her. Adam knowed what he was doing; Eve didn't know what she was doing, but Adam walked out with his wife. See?

And Jesus took His Wife's place and became sin for Her. Remember, He became you, He stood your punishment, that you might stand in His place. He stood in your place, that you might stand in His place. What a love! What a fellowship! How can we deny it? How can we do anything but love Him, friend? I could stay on it hours, but let's move on a little farther.

121 Now, there you are, “If the Bridegroom Spirit dwells in the Bride!”

122 When God made His first bridegroom, He made the bridegroom first, and he was both man and woman, in spirit; formed him in the dust of the earth, to make him material. And notice when He made Eve, from Adam, He took not another piece of clay, He took from the same piece of clay; the same Word, for Adam was a spoken Word. See?

He took from him, and then taken the...He had masculine and feminine spirit. And He took the feminine spirit away from Adam, and placed it in Eve; so it's still part of Adam's spirit, it's Adam's flesh. Then, it was Adam's spirit, the dynamic, that quickened the mechanics of his body.

123 So the Bride must also be flesh of His flesh, and bone of His bone. Then how is this mortal flesh going to become His flesh? We'll get to it in a minute, see. How is it done? How? What is this great transformation? Notice.

Now if the Spirit of him (God) that raised up Jesus from the dead dwell in you, he that raised up Christ from the dead shall also quicken your mortal bodies by his Spirit that dwelleth in you.

65-0418M - IT IS THE RISING OF THE SUN

124 Oh, my! The predestinated One, of course, like the Seed laid upon the earth, the One that had Life in them. Many of them were dead; they were just rotten seed; the waters and things burnt them out. But, you know, there was a Seed laying there ready for Life. God knowed It was laying there.

125 Now, the predestinated Ones are the first to be quickened by the Holy Spirit, for the Holy Spirit comes to claim Its Own. Now, this is deep now, and be sure to catch this good.

IT IS EXACTLY LIKE IN THE ORIENTAL
COVENANT

60-0716 - FROM THAT TIME

130 But in the days of Abraham in the Orient, the way they made a covenant was to take a beast, like a sheep or something, and kill it and cut it apart; and each one went in between these two pieces of the beast. Now, see what the little white Light was doing? And they wrote this covenant: “I do agree to do *such-and-such*, and *such-and-such*.”

60-0716 - FROM THAT TIME

131 Now, when they held this covenant between them, they said, “If we break this covenant—if we break this covenant, let our bodies be as this dead beast that we take it over.” Then they took the covenant, and they tore it apart like *that*; one, taking one piece, and one, another. They could never be duplicated.

60-0716 - FROM THAT TIME

132 You can never duplicate that piece of paper, no matter what you do. It's got to come right back and coincide, the pieces of letter that's tore between. You'd never be able to do it. One, carries one, and one, the other. And when this covenant is confirmed and brought, the oath is confirmed, then they bring these two pieces back together, and they match piece by piece.

60-0716 - FROM THAT TIME

133 Now, what was the Oriental covenant God was giving to Abraham? That through the seed of Abraham would come the Lord Jesus, the blessed One. God took Him up to Calvary and He tore Him apart, He separated His Soul from His body. And His body, God raised up on the third day, and took up and set on His right hand. And on the day of Pentecost, He sent down the Spirit that was in Jesus Christ, the Covenant with the Church.

60-0716 - FROM THAT TIME

134 And when the Church comes together in the resurrection, the same Spirit, was in Jesus Christ, that was tore out of Him, will have to be in the Church. You can't copy anything like It; you can't make nothing different from It. It's got to be the same Holy Spirit that dwelt in Christ. And when the rapture comes, when that Body come, His Bride that was tore from Him, or, the Holy Ghost will bring that Bride just exactly dovetail right into the Body of Jesus Christ.

60-0716 - FROM THAT TIME

135 And can you see from the days of Luther, to Wesley, to Pentecost, and now at the end time, how that Spirit's shaping up? The same signs and wonders that He did on earth is being done in the Church today. It's that covenant that God made with Abraham, and we are Abraham's children. "Being dead in Christ, we take on Abraham's seed and are heirs according to the promise." From that time, the Church had a covenant. Yes, it was different.

THE BRIDE IS THE KINDRED OF CHRIST: THEY
ARE BLOOD RELATION

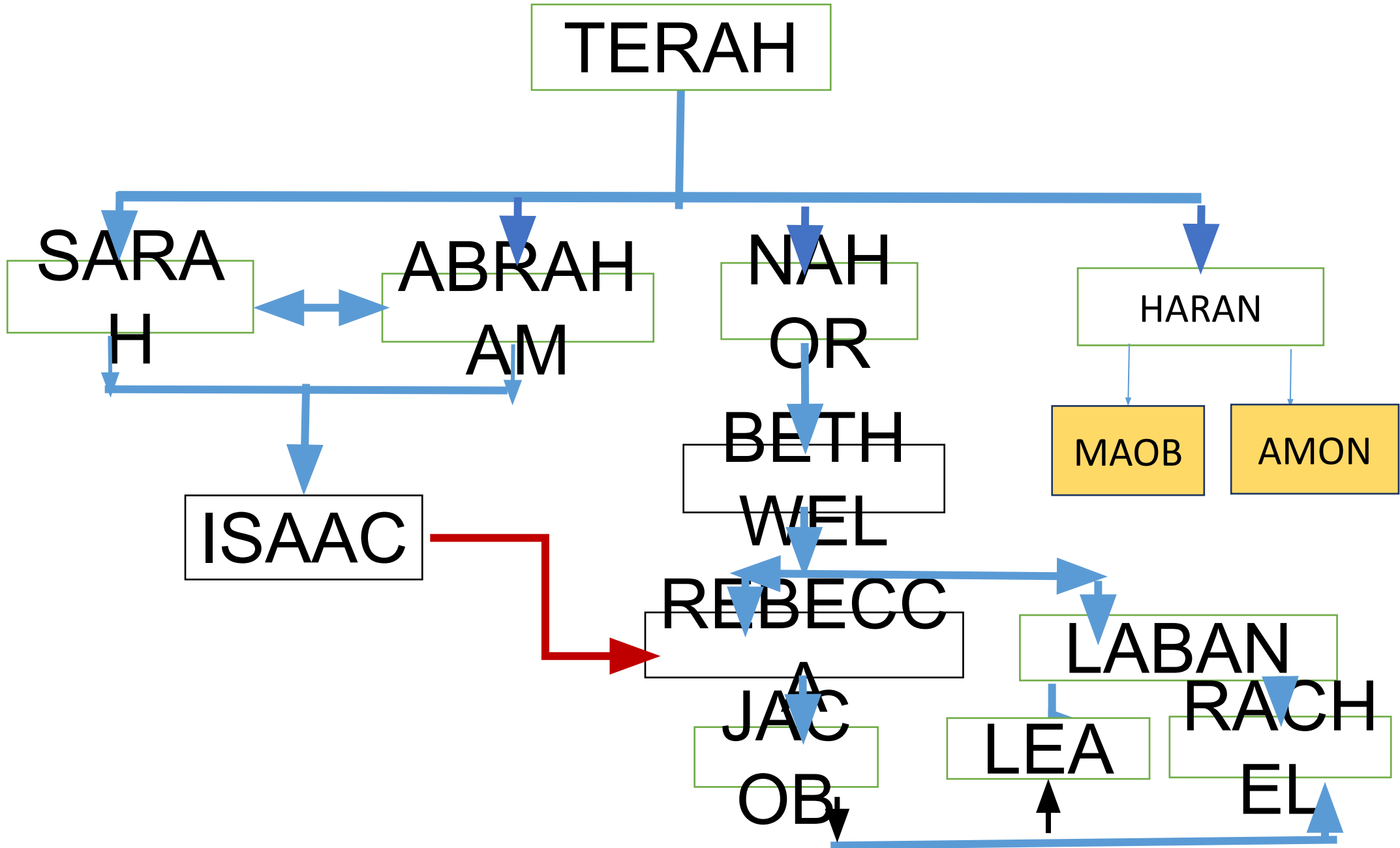

64-0830M - QUESTIONS AND ANSWERS #3

319 They're, see, they're strong. Like look here. Abraham married his own sister. Why, if a man'd marry his sister today, his children would be idiots. See? But the human...And here Jacob...or—or Isaac married Rebekah which was his own cousin, own blood cousin at that, blood relation, see, Abraham's brother's child.

64-0830M - QUESTIONS AND ANSWERS #3

252 And he said, “Go, don’t take him amongst the Philistines; don’t take her.” Get over here amongst his people, showing that the Bride of Christ and Christ is blood relation, ’cause Rebekah and—and Isaac were cousins.

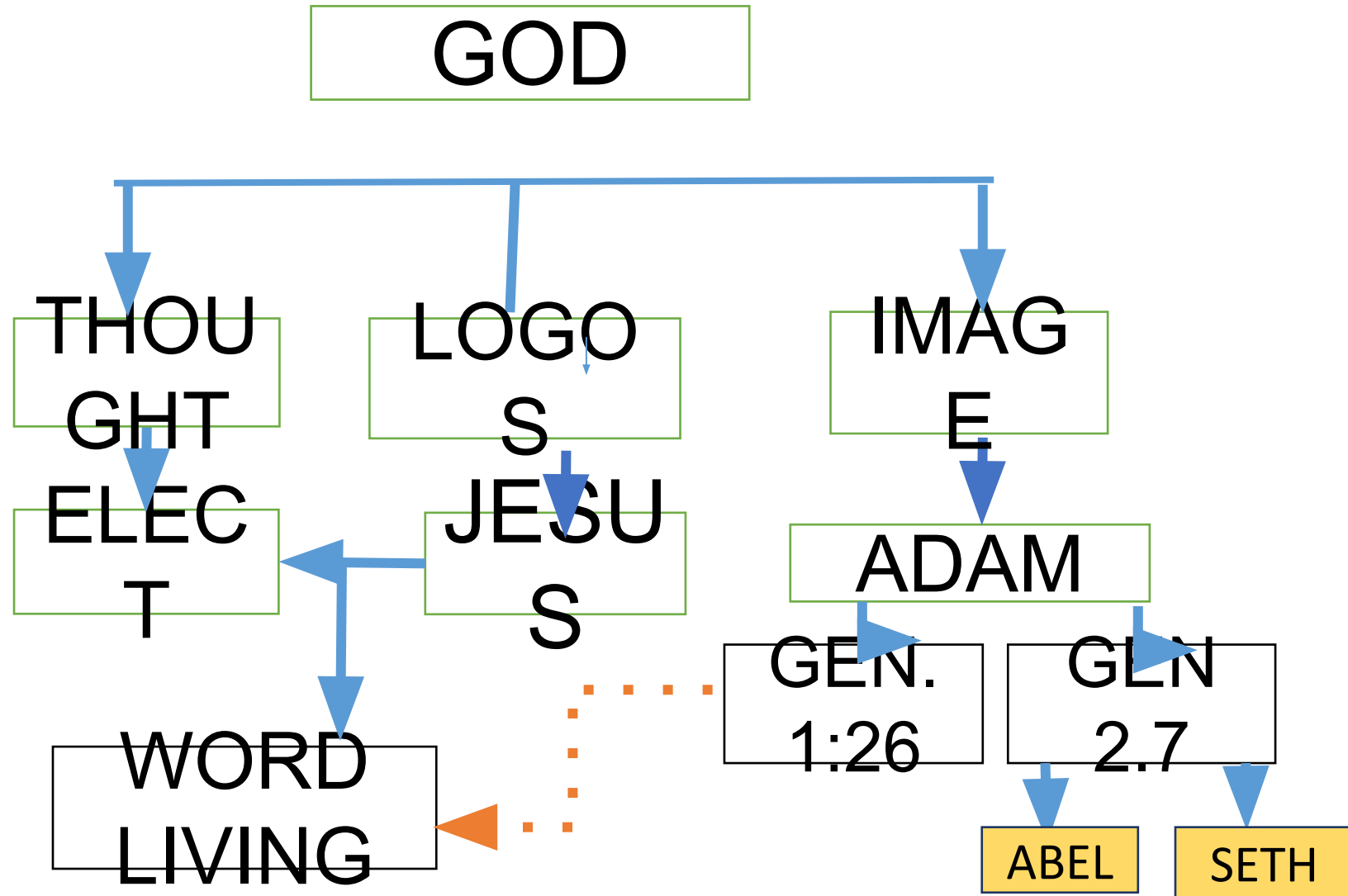

63-0428 - LOOK

259 They come, Blood relation, like Isaac and Rebekah, own Blood relation. That's what we have to come, Blood relation to Christ, through the Sacrifice, when our sins are omitted by the Blood of Jesus; not by what some church says, what somebody else says; but what the Blood has done, and proved that it's done, by the Word working through the same thing, carrying out the same ministry He had. Amen.

62-0708 - A SUPER SIGN

130 When Rebekah had been chose for Isaac, the son, it was also said the same to her. When Eliezer, a type of the Holy Spirit that come to find the Bride, he found her in the cool of the evening. Get what it is? This day, last day, last part of the day, when the evening Lights are shining, He found her.

134 Notice, Eliezer found the woman, he knowed that was her. And notice, he had to deal with two people, her mother and the brother. The father, rest of them, had nothing to say. Mother and brother!

135 So has the Messenger, the Holy Ghost of God, in this last days, picking out the Bride. He's had to deal with the church that calls itself the "mother," the Catholic; and the "brother," the preacher. That's exactly. He had to deal with those two. They was the one that kicked up a fuss about it.

136 But now he said, “You got to make your choice. Will you go?”

137 And look, quickly, as soon as she heard about Isaac, before she had ever saw him, she said, “I will go!”

62-0708 - A SUPER SIGN

138 Why? She was a blood relative to him. See, that was Abraham's brother's child. Isaac and Rebekah were first cousins, blood relation; showing that the Church in the last days will be Blood relation to Christ.

For the very God that predestinated the Christ,
Whose...was the Lamb slain before the
foundation of the earth, the Church itself, its
name, was put on the Book before the foundation
of the world. And Rebekah, as soon as she heard
of Isaac, there was something in her that pulled
her straight to him, though she hadn't seen him or
nothing, she yet wanted to go by her own choice
away from mother or brother.

62-0708 - A SUPER SIGN

139 And today, if that Light of God, that Holy Spirit, ever strikes a—a predestinated Seed, whose name was put on the Lamb's Book of Life before the foundation of the world! The Bible says that. That's right. The Light will shine! You can preach to some, and it seems like it's just like water on a duck's back, falls off.

But let it once strike that Seed, and watch what happens quickly, something is there right now! Why? It's predestinated Seed coming forth. It's got to come. And when that Light, the Gospel, strikes it, they get it. The rest of them will get up and walk away; it's not for them. The Bible said that men were "foreordained to condemnation," Book of Jude. All Scripture is by inspiration.

62-0708 - A SUPER SIGN

140 Now, when that Light struck little Rebekah, she knew something within her, and that brought her to Isaac. She veiled her face. She wanted no more to do with her own thinking. Isaac was her thinking from then on.

And the Church itself, when it strikes that Power of God, the baptism of the Holy Ghost, out of the denominational churches, out of the Catholic church, wherever it is! When that baptism of the Holy Ghost is made real to people, them that's predestinated (like you people here) to Eternal Life, sees It and walks in It. What is it? A super sign. And, the enemy, possess the gate of the enemy!

53-0729 - QUESTIONS AND ANSWERS ON GENESIS

125 That was all in type, showing that the...Here it is, brother! Isaac...Rebekah is a type of the Church, and Isaac is a type of the Bride, Christ. Is that right? And they must be Blood relation! Hallelujah! Amen! Blood relation!

ISAAC WAS A TYPE OF CHRIST AS REBECCA
WAS A TYPE OF THE BRIDE OF CHRIST

59-0418 - A TIME OF DECISION

39 Now, just in closing, I'd like to say this. On our little subject tonight, the decision...Eliezer...Did you notice, when he come...Now, Isaac was a type of Christ. Through Isaac come Christ. And then, Rebekah was a type of the Church. Did you notice the—the Bride...And Eliezer found Rebekah in the evening time. The sign was performed in the evening time. That's the time we're living in. I trust that you get this.

It was in the evening time when Rebekah came out led by the Spirit. Do you believe that? How otherwise would she have come? There might have been many before her. But she was led by the Spirit in the evening time. And Eliezer, the messenger, the minister, the true servant to his master, was led in the evening time. And the true servant had left his creeds and things behind him and made up his mind that he was going to trust God in the evening time.

59-0418 - A TIME OF DECISION

40 Wonder why that Rebekah came before any of the other girls. Did you know that Rebekah and Isaac was blood relation? Cousins. And the Bride of Jesus Christ is blood relation to Him: a Blood bought Bride. No wonder she was led by the Spirit. There was a connection coming together. There was a union coming together.

That's the reason I think today that the borned again, the—the Holy Ghost filled people is connected with God and are led by the Spirit of God. That's why they act so peculiar to the people. They've made their decisions. They're going to go on out; regardless if the rest of them don't go out, they're going anyhow. I like that.

Don't care if this one walks or that one walks, I'm going to walk anyhow. I don't care whether this one...of what they say, I don't...They call me anything they want to, I'm going anyhow. Why? The Life is in the Blood. And the Life is in the Church, the Christian that's borned again by the Spirit of God.

That's the Spirit of Life, Blood relation to Christ. The Spirit of Christ in the Blood of Christ leading a child of Christ, the seed of Abraham. That's why they move peculiarly. That's why the world thinks so strange of them.

59-0418 - A TIME OF DECISION

47 And Isaac is on his road. And as soon as Rebekah seen him, she flashed those pretty eyes upon him, she put the veil around her face and jumped off the camel and run to meet him. It was love at the first sight. He seen her and he loved her, took her into his father's tent and the wedding supper.

59-0611 - THE TIME OF DECISION

29 So why did Rebekah make that sudden move? Why did she go to the Waters of Life so quickly? Why could the Angel speak to her? Because she was a blood relation to Isaac. And that's who the Angel can speak to tonight is a Blood relation. By the Blood we are borned into the body of Christ. Rebekah was Isaac's own cousin by both fathers, which made them blood relation.

And the Bride of Jesus Christ is sanctified through the Blood of Christ, and an open vessel for the Holy Spirit to speak to. No wonder She'll come to the Waters of Life. "He that heareth, let him come to the waters of Life freely."

"The Bride said, 'Come.'"

"He that's a thirst, let him come."

"Blessed are ye when you hunger and thirst for righteousness, for you shall be filled." It's a promise of the Father.

59-0611 - THE TIME OF DECISION

30 She made her decisions quick. Watch her real quick then in the meeting. Quickly, if they're ordained to Eternal Life, they'll know it. There's something in the message that stirs them.

That's what stirred Rebekah. The message stirred her, Angel was leading her. Oh, can't you see the picture? The Angel of the Lord leading her. Then she was stirred.

59-0611 - THE TIME OF DECISION

35 O Lord, You see them, and You know them. Let the Holy Spirit now bring that Rebekah to the Waters of Life, where the cooling refreshing comes. The Presence of God shall bathe their hearts, souls, and bring unto them new life and new hope. Let the Angel of God, Who has been sent before the message, speak to the Blood relation that's been bought by the precious Christ.

THERE HAS BEEN CHURCHES AND CHURCHES BUT
THERE HAS GOT TO COME ONE! THE REAL BRIDE

65-0418M - IT IS THE RISING OF THE SUN

108 There has been churches, churches, brides,
brides, churches, brides, brides.

109 But there has got to come One! Hallelujah!
There has to come a real Bride! There must come
One that's not only got the Mechanics, but the
Dynamics of It, makes that Church live, move in
the Power of His resurrection.

65-0418M - IT IS THE RISING OF THE SUN

111 And as He, being the Groom, the Bride has to come forth, 'cause It's part of Him. And It can only be the manifestation of the fulfilling of all the revelations any others has spoke of the Bride; It can only manifest. If it does something different from the Groom, it isn't the Bride.

Because, She is flesh of His flesh, bone of His bone; Life of His Life, Power of His Power! She is Him! As man and woman are one, and woman taken from his side; She had taken a Spirit, the feminish Spirit, from Him. The flesh from His side, made both Mechanics and Dynamics, the Wife. The Spirit of Him and the flesh of Him, and put it together, and made Mechanics and Dynamics. Until the church or the people...

EPHESIANS 1:8-11

53-0729 - QUESTIONS AND ANSWERS ON GENESIS

59 Now, here it is, notice:

According as he has chosen us in him before the foundation of the world,...(whew!)

53-0729 - QUESTIONS AND ANSWERS ON GENESIS

60 That's pretty good. Isn't it? That's not pretty good, that's real good! Before there was a foundation of the world, God knew Orman Neville and knew that he would preach the Gospel. Isn't that wonderful? "Has chose..." Why, he's a member of the Church, and God knew He was going to have that Church.

And he said, Paul speaking to the church of Ephesus, said, “He has chosen us in Him.” Now, we’re all the members of the Body of Christ. Is that right? And God, before the world was ever formed, chose you and I in Him before the world was ever formed. Whew! My! Isn’t that wonderful?

61 Now, the first man, now, He made the first man in *His* image, and we are returning back to that image, that's right, to our first created image.

53-0729 - QUESTIONS AND ANSWERS ON GENESIS
62 When God created me, William Branham, I was before the foundation of the world, He made my being, my spirit. I wasn't conscious of anything as far as I know of, but the...I was there. Oh, I—I don't believe you're getting it. But now, just a minute, Jesus told the disciples that He "knew them before the foundation of the world," and Paul said here that "He chose us in Him before the world began."

Now, there was some part of me, Orman Neville, and the rest of you all here, that's in Christ Jesus before the world ever began. And here's to my analysis of that. I think that the people today that are possessed with this Spirit, or the spirit, a part of these angelic beings, spirits which rotated off of God, that never fell in the beginning and resisted the devil's lie in Heaven.

35 That's the reason you're holy this afternoon, not because you deserve it, but because He chose you to be that way. When? Before the foundation of the world.

...holy and without blame before Him in love:

How could we do it? There had to be a Masterpiece do that, and that was Christ Jesus. Listen, you don't remember it, neither do I; but we was before the foundation of the world.

When God made man said, “Let Us make man in our own image, let us give them (plural), let Us get...make man in our Own image (spirit man) and give them dominion over the fishes of the sea, and the cattle’s and so forth.” Genesis 1, God saying that, “Let Us make man.” ...

36 Now, back there before the foundation of the world, God chose you in Christ Jesus to appear holy at the end time, all the way from the foundation of the world. Do you see it?

Now, quickly, let's catch it now, next verse.

Having predestinated... (or elected) us unto the adoption of children by Christ Jesus to Himself, according to—to the good pleasure of His will, ...

37 May I speak to you just a moment? God before the world began...Notice, "No one," said Jesus, "can come to Me except My Father draws him." That's Jesus own Word. Here's the Blood cell; here it is broken; here's the spray of Blood a moving. Now, here's Christ inside this Blood cell. "Christ" means "the Anointed." It was the Anointed Blood cell.

Here It is in here. Here's God our Father; look at what He's doing. "No man can come through this Blood spray to Me, except My Father draws him. And all that comes, I'll give him Everlasting Life, no wise turn him out and will raise him up at the last day." You see what it is?

55-0116A - THE BELIEVER'S POSITION IN CHRIST

38 Now, look. He has chosen us for this purpose, having predestinated or foreknowledge, He fore-understood what it would be from the beginning. God in the beginning, knowing just what He would do at the end, He predestinated, or could foretell, what it would be: foreknowledge, foreknowing to be in Christ Jesus. Notice.

Having predestinated us unto the adoption of children...

The adoption, now we'll take the old laws just a moment again, then we'll have to close.

56-0603 - THE LAMB'S BOOK OF LIFE

177 Our Heavenly Father, we thank Thee this morning for Jesus. We thank Thee for the perfection of the Gospel, for the perfecting, and the Eternal sovereignty of God's Eternal, spoken Word. And according to His Word, He called us and chose us in Him before the foundation of the world, and wrote our names before the foundation of the world.

When God speaks a word, it's got to happen. It's just got to happen. And You spoke our names when You spoke His Name. You chose us, with Him, before the world began, so there's nothing we can say we could do, Lord. It's—it's not in mankind. There's nothing we can boast on or brag on.

The only thing we say, is, “God, thank You for Your grace. Thank You for Your mercy, Lord. Seeing that we were aliens, but now Thou has perfected us with that perfect Sacrifice that we stand in, O God, stand in Him, today, as we move on.” Thanking You, Father, for these things.

131 Who did it? God did it. God knowed from the beginning who would be saved and who wouldn't be saved. Certainly, He was not willing for any to perish. But He didn't send Jesus here just to see if you'd—you'd act like, "Well, poor Jesus, I feel sorry for Him. Maybe I'd better get saved and approve it." No, sir.

132 God knowed in the beginning who would and who would not. So, therefore, He knew that some would, so He sent Jesus to make a propitiation for those that He foreknew. “For those who He foreknew, He has called. And those who He has called, He has justified. And those who He has justified, He hath (past tense) glorified.” There you are.

133 So it's not you that keeps yourself, it's the grace of God that keeps you. You didn't save yourself, or nothing you done to deserve being saved. It's God's grace that saved you. God's grace called you. God's foreknowledge knew you. He knew that you'd be in this church this night, before the foundation of the world was ever laid, if He's infinite.

If He isn't, He isn't God. If He did know all things, He was God. If He didn't know all things, He wasn't God. If He's Almighty God, He can do all things. If He cannot do all things, He's not Almighty God. There you are.

57-0915E - HEBREWS, CHAPTER SEVEN #1

134 So how can you say it's something you could do? It's nothing you can do. It's God's love and grace to you, that you're even here. Nothing you could do, God called you by His grace; you listened, heard, accepted.

59-1223 - QUESTIONS AND ANSWERS

123 Before there was a world you were in God's thoughts to give you the Holy Ghost, because He knew that you'd be wanting It; and He chose you Himself because you desired...He chose you in Christ before you or Jesus, any of you, was on the earth.

And He sent Jesus to die, to prepare the way to send the Holy Ghost, to bring you to Himself. Hmm! Oh, that just...I know I may...This is the church, so I'm at home now, you see. Oh, that is so rich to me. To think it's not what I wanted; it wasn't my desires; it wasn't my will; it wasn't my choosing; I had not one thing to do with it. But before the world ever started, God saw us and put our name on the Lamb's Book of Life. Before there even was a world! Talk about God! Whew!

60-0911E - FIVE DEFINITE IDENTIFICATIONS OF THE TRUE CHURCH OF THE LIVING GOD

174 What did we do? Nothing. What He done is what I'm looking at. When did He do? Chose us, put our names on His Book, on His Church Book, to be a member of this mystical Body, before the world ever began.

And has predestinated us unto the adoption of children by Jesus Christ to himself, according to His Own good pleasure of his will,

60-0911E - FIVE DEFINITE IDENTIFICATIONS OF THE TRUE CHURCH OF THE LIVING GOD

175 Whew! You got to be in that Church, brother, if you make it, for He's coming for a Church. What kind of a church? "A Church that's without spot, or without wrinkle."

How can we be that? By being dead in Christ, baptized by the Holy Ghost into His mystical Body, and a Blood atonement of the Son of God laying there for us every hour of the day. “Found blameless,” that’s the Church, “without spot, or without wrinkle.” He chose us in Him, and put our names on His Book.

184 “Predestinated!” There’s the mystery. He, before Christ or anything else was ever on earth, you see His great mystery, that He chose the Bride. Knowing Eve would fall, from disbelieving the Word, knowing that she would fall; but He would choose a Bride that would not fall, that would hold to that Word regardless of what all the rest of the world had to say about It.

They would hold to that Word! They are predestinated to stand there, “the adoption of children by Jesus Christ,” predestinated the Church to that great, glorious stand!

185 Now you see His secret? What to? To restore fallen Eve, as she was a prefigure of the Church. And now notice, as God opened up the side of Adam and took out Eve, by his own flesh and blood; and divided his spirit from masculine and feminish, to feminish, and put it in Eve.

Took the rib from under his side, and made Eve out of it; so God did the same thing, taking out of the side of Christ, the Blood and the water. And Christ is the Word, and taking the Word and making up His Church, Eve; see, back to Himself again, redeemed by the Blood that was come from His Body. You see it now? [Congregation says, “Amen.” —Ed.]

186 God's great mystery now being unfolded, that's been hid since the foundation of the world, but prefigured it all the way down through. Now watch, we find that, that He—that He did that. And here in Ephesians, and many other places, but that will give you enough to... Now, down through the ages, He has been slowly unfolding this mystery. Can you see now? Now, down through the...

187 How did He...? What happened in the prefigure now? He opened Adam's side and took part of his flesh, which was Adam, to make Eve. The Bride has to be the Word, for He is the Word. She cannot stand on creeds. She cannot stand on denomination. She cannot stand on good behavior. She has to stand alone on the Word, because She is part of It. She was taken from Christ. See?

188 And to be sure, that, the whole Rapture now: Luther was a part, Wesley was a part, the prophets was a part. If they're—aren't a part...Just in the revelation that they was making up, the body, feet, toes, arms, and so forth, until the Head (which we get to that in a few minutes), see, that makes the entire Rapture. It's the Body of the Word, which is Christ. Amen!

189 Outside of That, you're lost. I don't care how good you are, or what your relationship is, or what your fellowship is, or what your organization is, you're lost, outside of that Word being in you.

190 “If ye abide in Me, the Word, My Word abide in you, then you ask what you will,” because you and the Word are the same. He has the preeminences. He’s got the rulership. You’re a—you’re a prisoner to Him. The world is dead. You have nothing more... You see the rest of the people living the way they do, but yet you do not do it.

You're a prisoner. You're yoked with Him. "My yoke is easy." Yoked with Christ, with His Word. "I do that only which the...pleases the Father. And if you can't believe that I am He, then believe the Word." So perfect! Notice.

191 Notice now, down through the ages, He has been gradually letting this out, slowly unfolding the mystery, through the prophets and through the types. Now we can just go on to that, and, expressing Himself.

63-0728 - CHRIST IS THE MYSTERY OF GOD REVEALED

192 He expressed Himself in Moses. Look at Moses. Born in the time of persecution of the children. He was born to be a deliverer. He was hid in the bulrushes, just like Jesus was taken down into Egypt. He came out. He went up on the mountain, come back with the commandments.

270 Same in the days of Elijah. Elijah, even to his bones, where that reflection... Reflector of God in his body being made manifest the Word of God. They laid a dead man on it, he sparked to life again. We are flesh and bone of Him, as long as we are the Bride of Christ. Do you believe that? All right.

He died for us, and we died to ourselves and are buried in His Name, that we would “no more be of the world, but in Him,” of which both the family in Heaven is named after Jesus Christ. That’s Ephesians 1:21. For both Heaven...the family in Heaven. What’s the family in Heaven named? Jesus.

What's the family on earth named? Well, that's the house of God where the Blood's at. Is that right? That's the door, that's the gate, that's the place He put His Name, and the Word was made flesh and dwelled among us. It's the Word reflecting and sparking off the age that you're living in.

That's what He was, that's what Moses was, that's what Jacob was, that's what the rest of them was, sparking off that Word of God, the reflector that God was reflecting Himself. And come to that perfect image of God, Jesus Christ, God's Masterpiece, Who was struck that He might take the rest of them for a Bride that's been reflectors.

65-1128M - GOD'S ONLY PROVIDED PLACE OF WORSHIP

271 Moses was in Him. Joshua was in Him. And if you are in Him, you was in Him before the foundation of the world, the family of God; you suffered with Him, you died with Him, you went to the cross with Him, you raised with Him; and now you're still with Him, setting in Heavenly places, reflecting the Message of the age to the world, the Light of the world.

“Ye are the Light of the world,” but if it’s hid by a denominational bushel basket, how are they going to see It? For your traditions, you make the Light of no effect! By trying... You denominationalists, trying to keep the Light away from your church; you won’t go in, neither will you let them. Amen.

YOU WAS IN HIM BEFORE THE FOUNDATION
OF THE WORLD

65-1128M - GOD'S ONLY PROVIDED PLACE OF WORSHIP
271 Moses was in Him. Joshua was in Him. And if you are in Him, you was in Him before the foundation of the world, the family of God; you suffered with Him, you died with Him, you went to the cross with Him, you raised with Him; and now you're still with Him, setting in Heavenly places, reflecting the Message of the age to the world, the Light of the world.

CAB 07 - SARDISEAN

THIS IS THE RECORD: GOD HATH GIVEN US ETERNAL LIFE, AND THIS LIFE IS IN HIS SON. HE THAT HATH THE SON HATH LIFE (ETERNAL) AND HE THAT HATH NOT THE SON HATH NOT LIFE (ETERNAL). *And those who have that life were in HIM before the foundation of the world.* THEY WERE CHOSEN IN HIM BEFORE THE FOUNDATION OF THE WORLD.

That GREAT ROYAL SEED, Jesus Christ, was planted (He died) and that life that was in Him came up through the wheat plant and is reproducing itself in multitudes of wheat seeds having the same life in them, and being like the Original because by Spirit they are original.

**ACCORDING AS HE HAS CHOSEN US IN HIM
BEFORE THE FOUNDATION OF THE WORLD**

53-0729 - QUESTIONS AND ANSWERS ON GENESIS

59 Now, here it is, notice:

According as he has chosen us in him before the foundation of the world,...(whew!)

60 That's pretty good. Isn't it? That's not pretty good, that's real good! Before there was a foundation of the world, God knew Orman Neville and knew that he would preach the Gospel. Isn't that wonderful? "Has chose..." Why, he's a member of the Church, and God knew He was going to have that Church.

And he said, Paul speaking to the church of Ephesus, said, “He has chosen us in Him.” Now, we’re all the members of the Body of Christ. Is that right? And God, before the world was ever formed, chose you and I in Him before the world was ever formed. Whew! My! Isn’t that wonderful?

61 Now, the first man, now, He made the first man in *His* image, and we are returning back to that image, that's right, to our first created image.

53-0729 - QUESTIONS AND ANSWERS ON GENESIS

62 When God created me, William Branham, I was before the foundation of the world, He made my being, my spirit. I wasn't conscious of anything as far as I know of, but the...I was there. Oh, I—I don't believe you're getting it. But now, just a minute, Jesus told the disciples that He "knew them before the foundation of the world," and Paul said here that "He chose us in Him before the world began."

Now, there was some part of me, Orman Neville, and the rest of you all here, that's in Christ Jesus before the world ever began. And here's to my analysis of that. I think that the people today that are possessed with this Spirit, or the spirit, a part of these angelic beings, spirits which rotated off of God, that never fell in the beginning and resisted the devil's lie in Heaven.

56-0603 - THE LAMB'S BOOK OF LIFE

177 Our Heavenly Father, we thank Thee this morning for Jesus. We thank Thee for the perfection of the Gospel, for the perfecting, and the Eternal sovereignty of God's Eternal, spoken Word. And according to His Word, He called us and chose us in Him before the foundation of the world, and wrote our names before the foundation of the world. When God speaks a word, it's got to happen.

It's just got to happen. And You spoke our names when You spoke His Name. You chose us, with Him, before the world began, so there's nothing we can say we could do, Lord. It's—it's not in mankind. There's nothing we can boast on or brag on. The only thing we say, is, "God, thank You for Your grace. Thank You for Your mercy, Lord. Seeing that we were aliens, but now Thou has perfected us with that perfect Sacrifice that we stand in, O God, stand in Him, today, as we move on." Thanking You, Father, for these things.

57-0915E - HEBREWS, CHAPTER SEVEN #1

131 Who did it? God did it. God knowed from the beginning who would be saved and who wouldn't be saved. Certainly, He was not willing for any to perish. But He didn't send Jesus here just to see if you'd—you'd act like, "Well, poor Jesus, I feel sorry for Him. Maybe I'd better get saved and approve it." No, sir.

57-0915E - HEBREWS, CHAPTER SEVEN #1

132 God knowed in the beginning who would and who would not. So, therefore, He knew that some would, so He sent Jesus to make a propitiation for those that He foreknew. “For those who He foreknew, He has called. And those who He has called, He has justified. And those who He has justified, He hath (past tense) glorified.” There you are.

57-0915E - HEBREWS, CHAPTER SEVEN #1

133 So it's not you that keeps yourself, it's the grace of God that keeps you. You didn't save yourself, or nothing you done to deserve being saved. It's God's grace that saved you. God's grace called you. God's foreknowledge knew you.

He knew that you'd be in this church this night, before the foundation of the world was ever laid, if He's infinite. If He isn't, He isn't God. If He did know all things, He was God. If He didn't know all things, He wasn't God. If He's Almighty God, He can do all things. If He cannot do all things, He's not Almighty God. There you are.

57-0915E - HEBREWS, CHAPTER SEVEN #1

134 So how can you say it's something you could do? It's nothing you can do. It's God's love and grace to you, that you're even here. Nothing you could do, God called you by His grace; you listened, heard, accepted.

60-0911E - FIVE DEFINITE IDENTIFICATIONS OF THE TRUE CHURCH OF THE LIVING GOD

174 What did we do? Nothing. What He done is what I'm looking at. When did He do? Chose us, put our names on His Book, on His Church Book, to be a member of this mystical Body, before the world ever began.

And has predestinated us unto the adoption of children by Jesus Christ to himself, according to His Own good pleasure of his will,

60-0911E - FIVE DEFINITE IDENTIFICATIONS OF THE TRUE CHURCH OF THE LIVING GOD

175 Whew! You got to be in that Church, brother, if you make it, for He's coming for a Church. What kind of a church? "A Church that's without spot, or without wrinkle."

How can we be that? By being dead in Christ, baptized by the Holy Ghost into His mystical Body, and a Blood atonement of the Son of God laying there for us every hour of the day. “Found blameless,” that’s the Church, “without spot, or without wrinkle.” He chose us in Him, and put our names on His Book.

THEY COULDN'T SEE HIM THEY WON'T SEE
HIM TODAY.

BUT YOU ARE THE VEIL THAT VEILS CHRIST

64-0614M - THE UNVEILING OF GOD

270 Notice. Then, we, then we become part of Him, as you are the veil that veils Him. You are part of Him, as long as Christ is in you, as Christ was of God. Because God was in Him, made Him God. And as Christ is in you, the hope of Glory, you become part of Christ. “He that believeth on Me, the works that I do shall he also.”

See? You become part of Christ as long as Christ is hid in you. Then it's veiled to the unbeliever, but you know He is in you. You are temple-ing Christ that's behind the veil, the skin. Then we, becau-...Behind, because of this veil, the veil again in human flesh, hides God (the Word) from the unbeliever.

64-0614M - THE UNVEILING OF GOD

271 As it is written, see, “Written, you are written epistles,” the Bible said. Now, what is *epistle*? Is a “written word.” And you are the “written.” Other words, you’d read It like this, “You,” It said, “you are written epistles,” or, “you are the Word, that has been written, made manifest,” nothing can be added to It.

You can't say, "I'm a written epistle," and living some other kind of a something but what *This* has already wrote, [Brother Branham pats his Bible—Ed.] because nothing can be added or taken away.

64-0614M - THE UNVEILING OF GOD

194 So notice the veil, the human flesh. No, now, the sin-loving people could not see that. Those traditional religious people, they couldn't see that, because He was a man. Why? That human flesh hid God.

64-0125 - TURN ON THE LIGHT

39 Now, Jesus was all the inspired prophets' testimonies. And all their prophecy was brought to Light in His age, that had been prophesied for His age. He lit up every candle of Word that was in the Bible, that was prophesied of Him.

“A virgin shall conceive.” She did. All right. “His Name shall be called Counsellor, Prince of Peace, Mighty God, Everlasting Father.” He was. “And the eyes of the blind shall see.” They did. Everything that was prophesied of Him, happened when He come on earth.

64-0125 - TURN ON THE LIGHT

40 And why the people could not see that, that was...It seems strange to us now, because we are looking back through a rear-view mirror. But did you ever know, if you keep looking back that way, you'll wreck? Let's look what's ahead for us.

64-0125 - TURN ON THE LIGHT

41 That's what they were doing. The reason that they did that, because they were living in a glare of another light. There were living in the glare of the light of another day.

64-0125 - TURN ON THE LIGHT

42 And that's what I believe is the matter with the world today, friends, is because we are trying to live in a glare of a light that shined in another day. A glare is a false light.

64-0614M - THE UNVEILING OF GOD

188 Notice now, the veil in human flesh, the promised Word to this age must also be veiled. Notice. Sin-loving church members and sinners cannot see It because of the human veil.

64-0614M - THE UNVEILING OF GOD

189 That's the reason they couldn't see Him. "Why, He's a man. Where did He come from? What fellowship card does He have? What church does He belong to?" I want to speak on that tonight, "What church does He belong to?" See? And so, see, now, "What church does He belong to, what—what group? What school did He have?"

Where did He get His education? Well, this Man was born, according to the tradition, or according to the—the legend of Him around here, this Man was born out of holy wedlock. Why, He, sure, He's of the devil. See, He's—He's of the devil. He was born out of holy wedlock, and Joseph just married her to keep her from being stoned, 'cause she was an adulteress. And that Man come around and tell us priests what to do?"

64-0614M - THE UNVEILING OF GOD

190 And there was God standing there, revealing that Word, crying, “My God, why has Thou forsaken Me?” The very songs they were singing in the temple, that David had made for them years ago, pertaining to Christ. “All My bones they stare at Me. They pierced My hands and My feet.” And there they was standing there, singing that, and the very Man dying on the cross. And when they got through and the...

64-0614M - THE UNVEILING OF GOD

191 When He died, the God of Heaven come down, like He did on Mount Sinai, with Holy Fire, and burnt that temple veil from top to bottom, tore it apart. And what could they do? Look right there out of the temple window, on Calvary, and there was God in plain view, the Sacrifice.

64-0614M - THE UNVEILING OF GOD

192 But they don't see It yet, today. God in this last day has rent those traditions away, and brought the Word for this age right plain in view, and they still don't know It. They just don't know It. It's—it's so simple. See, it's just so simple. It's so far away from the things of the world.

64-0614E - THE ODDBALL

96 Now, it won't thread up with a denomination. It'll only thread with the Word. But there is some people in the world believes that Word! It'll take a nut to wrap that Bride out of here, is threaded, for the Bride and the Bridegroom are one. And the God is one, and the Word is God! It'll have to be threaded with the Word, and It'll draw the Bride out of these denominations.

WHO IS THIS JESUS THE HUSBAND MAN

CAB 02 – PATMOS

Revelation 1:12, “And I turned to see the voice that spake with me. And being turned, I saw seven golden candlesticks.” John does not say that he turned to see the one whose voice he heard, but he turned to see the voice. Oh, I like that. He turned to see the voice. The voice and the person are one and the same. Jesus is the WORD.

John 1:1-3, “In the beginning was the Word, and the Word was with God, and the Word was God. The Same was in the beginning with God. All things were made by Him; and without Him was not any thing made that was made.” If you can ever get to really see the Word you will be seeing Jesus.

CAB 05 – PERGAMEAN

John 1:1-3, “In the beginning was the Word, and the Word was with God, and the Word was God. The Same (Word) was in the beginning with God. All things were made by Him; and without Him was not anything made which was made.” I John 5:7, “There are three that bear record in Heaven, the Father, the Word, and the Holy Ghost: and these three are ONE.” Now we can see His association with the Word. HE IS THE WORD. That is Who He is. *THE WORD* IN HIS NAME.

64-0617 - THE IDENTIFIED CHRIST OF ALL AGES

84 But He was more than a prophet. He was the God-Prophet. What David was, what Moses was, what Elijah was, what all of it was, “in Him dwelt the fullness of the Godhead bodily.” He was the God-Prophet.

He was God, Jehovah, became a flesh in His Own Son, raised Himself up a tabernacle to manifest Himself in. All the rest of them failed, they had flaws; but there is no flaw in Him. Even God Himself said, “This is My beloved Son in whom I am pleased to dwell in.” That’s right, no flaw in Him. “Hear ye Him!” He was manifested God.

64-0617 - THE IDENTIFIED CHRIST OF ALL AGES

85 They said, “You make Yourself God, or equal with God.” He was. He was His Own Son. Amen. He had...He was the manifestation of God. God was in Christ, reconciling the world to Himself.

64-0617 - THE IDENTIFIED CHRIST OF ALL AGES

86 And in this last day, He speaks to the people through His Son, Christ Jesus, making Himself known. Then what is Christ? The Word. The Word of what, the word of Moses? Yes, but today He is the Word manifested for this day.

65-0815 - AND KNOWETH IT NOT

118 “All the fullness of all things.” All the fullness of God, all the fullness of Angels, all the fullness of time, all the fullness of Eternity; everything dwelt in Him. That’s this Fellow.

And, having made peace through the blood of his cross, by him to reconcile all things unto himself; by him, I say, whether they be things in earth, or things in heaven.

65-0815 - AND KNOWETH IT NOT

119 There is that great Being we're talking about, "The beginning of the creation of God."

120 Now, now that, the Church, that His very whole purpose was the Church. Now how do we get into this Church? "By one Spirit we're all baptized into one Body," the Church, the Body of Christ. It cannot fail.

HE WAS THE LOGOS THAT WENT OUT OF
GOD

50-0815 - WHO IS GOD?

15 And there, that great space where no one can fathom in their mind beyond that, that space, eternity. That's Jehovah God out there. And we're taught in the beginning, that the Logos, or the Son of God went out of God.

Now, I do not believe in eternal sonship. That's even radical to even mention such a thing, eternal sonship. How...He had a eternal sonship...?...way, it's even eternal sonship, how could He be a Son? He had to have a beginning. See?

50-0815 - WHO IS GOD?

16 So He first was God, Jehovah. And out of Him...Let's just picture now as a little drama so you can get it. Let's see coming out of space where there's nothing, let's make it a little white Light, like a mystic Light, like a Halo. And that was the Logos that went out of God in the beginning.

That was the Son of God that came out of the bosom of the Father. That was what was in the beginning was the Word, and the Word was with God, and the Word was God. And the Word was made flesh and dwelled among us. In the beginning was God. And then out of God came the Logos, a part of God that went out of God.

56-0225 - JESUS CHRIST THE SAME YESTERDAY, TODAY, AND FOREVER

17 And so now, in this, Jesus raised the...I want to know tonight before I start. How many in here really believe the Bible, Jesus Christ did raise from the dead, let's see your hands, you believe it? All right. If He has risen from the dead, then He's got to be the same yesterday, today, and forever, is that right?

Then He's got to be the same in principle, the same in power, and everything that He was, outside of a—of a—a corporal body, He is tonight. Don't you believe that? And He came from God. He's been here on earth. And He came from Spirit. He was with the Father before the foundation of the world. And He was the Logos that went out of God.

And then, when He...Then He was made flesh and dwelled among us. And then we could touch Him with our hands. Then He turned back to God again. He said, "I come from God and went to God."

56-0401M - THE MIGHTY CONQUEROR

95 When He was in Heaven, He was the “Logos” that went out of God, in the beginning. And He came down on earth, and was not to be made an Angel. He came down on earth and took the form of a bondsman, not an Angel; not come down in the great Jehovah Glory. But He came down as a Man, to redeem man, to die for man, to die for...as a man. He never died as God. He died as a man. The sin of man was upon the Son of man. And He had to become a Man, in order to pay the penalty

57-0421S - THE GREAT AND MIGHTY CONQUEROR

27 And then He came, He came down. Because, “He was in the beginning,” the Bible said, “He was the Word.” He was the Logos that went out of God. And the Logos, in the beginning, was the Word. And He became the Word. Then when He ascended up on that glorious day of Easter, He become not only the Word, but He become the High Priest of His Own Word.

Oh, what a glorious thing, Brother Neville! Just think! He's not only the Word, but He is the High Priest of His Own Word. How could we doubt it? How could we walk to Him and not believe that we receive what we ask for? For, He is the Word and the Intercessor of the Word! The Logos became Word, and the Word made flesh; and the same flesh that was the Word, received up into Glory, and now is the High Priest making intercession, by Himself, to His Word.

THE BRIDE WAS IN HIS THINKING

64-0304 - SIRS, WE WOULD SEE JESUS

12 God is Life, Life Eternal. “In the beginning was God.” He wasn’t God at that time, because *god*, the English word *god*, means “object of worship,” and there wasn’t nothing but Him. He was the Eternal, just the Eternal One. There was no moon, no stars, no Angels, no nothing. But in this Being, that we call “God our Father,” was attributes.

In Him was attribute to be Father, in Him was attribute to be God, in Him was attribute to be Son, in Him was attribute to be Saviour, in Him was attribute to be Healer, and all these things that we see now is just displaying His attributes.

64-0304 - SIRS, WE WOULD SEE JESUS

13 Now, if you were in His thinking, at the beginning, if you've got Eternal Life, there is only one form of Eternal Life. Eternal Life had no beginning and it has no ending. So if you have Eternal Life, you were an attribute of God's thinking before there was anything but Him.

65-0221E - WHO IS THIS MELCHISEDEC?

50 And remember, you, your eyes, your stature, whatever you was, you were in His thinking at the beginning. And the only thing that you are is expression, word. After He thought it, He spoke it, and here you are. If it isn't, if you wasn't in His thinking, there is no way at all for you ever be there, for He is the One that gives Eternal Life.

YOU WERE IN HIS THINKING, YOUR NAME
AND ALL

65-0410 - THE EASTER SEAL

59 There's only one Life, one Eternal Spirit, one Eternal Life, and that's God. God, alone, is the Eternal. And then we, being His children, are part of Him, that is, the attributes of His thinking. And the thought is expressed and becomes a word. Then, each individual in here, that possesses this Eternal Life, was before the foundation of the world, in God's thinking.

It's the only way it could be, 'cause you're a attribute. That's an expression of a thought, has become a Word; and a Word has taken Life, and it's Eternal. That's the reason we have Eternal Life. In the same principle that the great Son of God, the Redeemer; we become sons and daughters of God, through that same Spirit, by the same foreknowledge of God.

65-0410 - THE EASTER SEAL

62 But remember, you, in the—the stature that you are in, this morning, if you wasn't in His thinking then, you're not now. For you, there's some part that's in you, that's Eternal, and Eternal only belongs to God. And in God was His thinking of you setting right where you are now. In His thinking, I stood at the pulpit this morning, because He's infinite and knows all things.

Therefore He could tell the end from the beginning, because He is Eternal. And you, being a son of God or a daughter of God, then you were in His thinking at the beginning.

65-0410 - THE EASTER SEAL

63 And then when the Holy Spirit come, and you're on earth, walking around here as a sinner, way down in your life there is something. You don't know what's taking place, but you're hungering. I heard the Presbyterian brother; I heard the—the Baptist talking about, back there, he was a—a Freewill Baptist, preaching where he can.

My fellow brother, that you, there's something in you, something that you never put in there. It's something that you couldn't desire to be in there. It's something that's contrary to your own nature. It's the foreknowledge of God, taking place, God's Word.

65-1127E - I HAVE HEARD BUT NOW I SEE

195 Only can the rain raise the seed, if the seed's already there. And as you was a germ first in your father, and he didn't know you, yet you were in your father. But through a bedding ground of your mother, you were made manifest in his likeness, and then he could talk to you. God, the Great God; if you've got Eternal Life, then the germ of Eternal Life was in God at the beginning.

And you were there, you were in His thinking, your name and all. And He, by foreknowledge, ordained you to see This. And you that was not ordained, will never see It. But, remember, in the Name of the Lord Jesus, “The hour is here!” Won’t you believe Him? Give your lives to Him. I have to stop, it’s after nine.

SO WHO IS THIS ONE THAT'S CALLED THE
BRISE OF CHRIST

59-1223 - QUESTIONS AND ANSWERS

49.....Jesus said, “Heavens and earth will pass away, both heavens and earth may pass away, but My words will never pass away.” See? They’re eternal with God. And “If ye abide in Me and My Word in you...”
See? We become a part of His Word, part of His Life, for we are flesh of His flesh, and bone of His bone, and life of His Life. Then we can no more perish than God Himself could perish. That’s what the Holy Ghost is.

65-0418M - IT IS THE RISING OF THE SUN

111 And as He, being the Groom, the Bride has to come forth, 'cause It's part of Him. And It can only be the manifestation of the fulfilling of all the revelations any others has spoke of the Bride; It can only manifest. If it does something different from the Groom, it isn't the Bride. Because, She is flesh of His flesh, bone of His bone; Life of His Life, Power of His Power! She is Him!

**IT IS OUR TURN TO BECOME THE SPOKEN
WORD SEED**

64-0705 - THE MASTERPIECE

161 The Word, living and in action, the Bible Bride, not some man-made bride; the Bible Bride, smitten and afflicted of God. “No beauty we should desire Her, but yet we did esteem Her smitten and afflicted of God.” That’s right. She stands alone. She is smitten from all the denominations, according to Revelation 3. She is smitten out of the Laodicean Church Age that She was raised up in. See?

CAB 04 – SMYRNAEN

Down through the centuries we could go. We find a Moses, a Jeremiah, a John the Baptist, and each one of these were God's eternal thought expressed in its season. Then we come to Jesus the LOGOS. He was the perfect and complete THOUGHT expressed and He became known as the Word. That is what He IS, and *forever* WILL BE.

Now it says that “He hath chosen us IN HIM (Jesus) before the foundation of the world.” That means that we were right there WITH Him in the mind and thoughts of God before the foundation of the world. That gives an ETERNAL quality to the elect. You can’t get away from that.

CAB 04 - SMYRNAEN

In very plain language the True Bride of Christ was in the mind of God eternally, though not expressed until each came forth in the designated, decreed season. As each *member* came forth it became EXPRESSED and took its place in the body. Thus this bride is the literal SPOKEN WORD SEED BRIDE. And though she is feminine in designation she is also called the “body of *Christ*.”

It is very apparent that she ought to be called that for she was predestinated in Him, came from the same source, was eternal with Him, and is now manifesting God in a many-membered body whereas once God was manifested in ONE MEMBER, even our Lord Jesus Christ.

Now then, here we are coming to a conclusion. As the eternal Logos (God) was manifest in the Son, and in Jesus dwelt all the fulness of the Godhead bodily, and that Eternal One was the Father manifest in flesh, and thereby gained the title of Son, even so we, eternal in His thoughts in our turn became the many-membered Spoken Word Seed, manifest in flesh, and those eternal thoughts now manifest in flesh are the sons of God, even as we are so called.

WE DID NOT BECOME SEED BY THE REBIRTH, WE WERE SEED AND THEREFORE WERE REBORN FOR ONLY THE ELECT CAN BE REBORN. Because we WERE SEED is the reason we could be quickened. In NON-SEED there is nothing to quicken.

CAB 04 - SMYRNAEN

Hold this carefully in mind. Now take the next step. Redeem means to buy back. It restores to the original owner. God, by His death, the shed blood BOUGHT BACK HIS OWN. He bought back the Spoken Word Seed Bride. “My sheep hear My voice (Word), and they follow Me.” You always were a sheep. You never were a pig or a dog turned into a sheep.

“PREDESTINATED!” THERE’S THE MYSTERY

63-0728 - CHRIST IS THE MYSTERY OF GOD REVEALED

183 When did He choose us? “Before the foundation of the world,” when His great hidden mystery, His great secret.

...He chose us in Christ before the foundation of the world, that we should be holy and without blame before him in (what?) love:

Having (what?) predestinated us unto the adoption of children by Jesus Christ to himself, according to the good pleasure of his will,

**THE REVELATION OF CHRIST IN THIS DAY IS
WHERE THAT CHURCH IS BUILT**

65-1205 - THINGS THAT ARE TO BE

36 You see, the whole—whole program, the whole Church, is built upon Divine revelation. Jesus said, in Saint Matthew, the 16th chapter, “Flesh and blood has not revealed this to you, but My Father which is in Heaven has revealed this to you.” What was it? A revelation of Who He was. “And upon this rock, I’ll build My Church, and the gates of hell can’t prevail against It.” See?

The revelation of Jesus Christ in this hour, not what He was in another hour, what He was now, the Bible expresses, it's growing in the Bride, to the full stature. Therefore, if the corn of wheat, of Christ, had to fall in the ground, so did the Bride have to fall in the ground, through the dark ages. Any grain that goes in the ground must die, or it can't produce itself, reproduce itself.

And the great Church that He established on the Day of Pentecost, by the sending of the Holy Ghost, had to suffer martyrdom and go into the dirt, into the earth in the dark age, to bring forth again in the age of Luther, and come on out to the full stature of the Bride of Jesus Christ for this last day. See? There's no way...

65-1205 - THINGS THAT ARE TO BE

37 Therefore, the Bride, in the Rapture, will come forth. And there is all pre-planned by God, all backed up. From the beginning, He knowed every man, every place, who would set, all about it. It's all pre-planned. God knew it would be here.

And—and when...He made it that way, so that when we get there...He's gone to prepare a place for us. And when we get there, it'll all be prepared just like even this night is prepared, like this hour is prepared. Yes. His great foreknowledge tells Him all these things, by foreknowledge.

65-1205 - THINGS THAT ARE TO BE

41. I don't believe in a...that a person just happened to be here by chance. Now just think, when you come to the—the world, everything had to be fore-prepared for you, or pre-prepared, rather, for you. I don't hardly understand that how that we could think that a God that could prepare all these good things for us would not...we could not put trust in Him.

That, if He brought us in this chaos that we're in now, and prepared the good things of life for us here, how much more can we trust Him to prepare the things that is to come, see, the Eternal things! It seems, I say, very strange.

**ONLY A SON CAN RISE, ONLY A SON CAN
RESURRECT, AND ONLY A SON CAN
RAPTURE**

65-0418M - IT IS THE RISING OF THE SUN

97 “Because I live, ye live also,” speaking to His

Wife. “Because I live, ye live

also.” What a resurrection that that was! And what a resurrection this is, to be quickened from the dead, “to be made alive in Christ Jesus,” by God’s quickening Power.

52-0713A - EARLY SPIRITUAL EXPERIENCES

28 Oh, we're living in the day of Christ, the power and the resurrection and the Holy Ghost. People are... Time to quit playing church. This form and ritualistic ideas is all right. The hour will come when you'll see that I've told you the truth. That's right. Of course, it's hard now. I know it is. But I speak in the Name of the Lord. And I know what I speak of. God testifies the same; that it's the truth. All right.

60-0716 - FROM THAT TIME

134 And when the Church comes together in the resurrection, the same Spirit, was in Jesus Christ, that was tore out of Him, will have to be in the Church. You can't copy anything like It; you can't make nothing different from It. It's got to be the same Holy Spirit that dwelt in Christ. And when the rapture comes, when that Body come, His Bride that was tore from Him, or, the Holy Ghost will bring that Bride just exactly dovetail right into the Body of Jesus Christ.

65-0218 - THE SEED IS NOT HEIR WITH THE SHUCK

61 Neither can the spiritual be...the natural be heir with the spiritual. No more can Ishmael's children be heir with the—with the Isaac's children, and no more than the carnal can be heir with the spiritual.

65-0218 - THE SEED IS NOT HEIR WITH THE SHUCK
62 Church natural; Church spiritual. There is a church
natural that these women here type; and there's a
Church spiritual, also. So, the natural church and the
spiritual Church cannot be heirs together. They are two
different, separate times; two different, separate
peoples; under two different, separate covenants.

65-0218 - THE SEED IS NOT HEIR WITH THE SHUCK
63 That's why the Rapture is different, and will only be for the royal Seed of Abraham. It cannot come by the natural, carnal seed of the church. It'll have to be the royal Seed of the Word of God, through Abraham, the royal Seed. That's why the Rapture has to be first.

Cause, remember, “We which are alive and remain shall not hinder, prevent those which are asleep. For the trumpet of God shall sound, the dead in Christ shall rise first. We which are alive and remain shall be caught up with them, together, and meet the Lord in the air.” Notice, and again it’s written, “And the rest of the dead lived not, for a thousand years.”

65-0218 - THE SEED IS NOT HEIR WITH THE SHUCK

64 Therefore, there, they will not be heirs together.

They'll not be

in the Rapture together. There is absolutely a church natural, and Church spiritual; a church carnal, a Church spiritual. Then, see, here is no...

WE ARE SONS OF GOD

56-0527 - AT KADESH-BARNEA

47.....Because, we're offsprings of God, sons and daughters of God. No matter how fallen we are, still we have to recognize that we are sons and daughters of God. In our fallen estate, we're still sons and daughters.

53-1120 - DEMONOLOGY

74....He's setting by the Father, He sent the Holy Spirit back, the third person, the Trinity, to bear record of His being, which *is* God. That's God in us. And the Bible said that we become (Jesus said) we become gods, in a form; Scripture says so. See? We are gods. Because why? We are sons of God. I—I'm...In that way we are, because, just like, I'm a Branham because I come out of that Branham branch. And we are s-...In that way because we—we are sons of God, offsprings of God. You believe that?

54-0228A - EXPECTATION

39 Well, now, the same thing...Many things that we have that we favor of—by a family strain like that to each other. And then in the family strain of God, if we become born of the Spirit of God, we take on the nature of God. Which, then we are sons of God.

And there's where I find that the Full Gospel people has become sons and daughters of God. They believe the supernatural. Now, the other has never stepped up there, so they can't believe the supernatural. There's nothing to believe with. See?

54-1203 - THE LAW HAVING A SHADOW

42....And God being manifested in the flesh with Christ Jesus the Anointed, wrapped Himself in a Blood Cell (Oh, my.) in the womb of Mary, brought forth His Life. He lived a Man; He died a Man to give His Blood, that through His body, and the shedding of His Blood that every believer could be wrapped in that Blood Cell with Him.

Which is a borned again Spirit of a man is wrapped in the Blood Cell of the Son of God, and God can no more deny you than He could deny Himself. For by one Spirit we're all baptized into one Body, and become partakers of the same Spirit that's in this Blood Cell. And the Church is wrapped into the Blood Cell of the Life of Jesus Christ. Hallelujah. Then we are sons of God, joint-heirs with Jesus Christ in the Kingdom.

**THE FULL WORD IS TO BE BORN IN
MANIFESTATION**

65-0218 - THE SEED IS NOT HEIR WITH THE SHUCK
100 But when the Seed was delivered, It said, "I
come to do the will of Him that sent Me. I and My
Father are One. If I do not His works, believe Me
not." There was the Seed. "Which one of you can
condemn Me of unbelief? What the Bible has promised I
would do, I done it.

God has verified that through Me,” He said. “Who can tell Me now?” See? But, the the Seed in Mary, the shuck, it was close to being That, but it wasn’t. It was still in the womb.

101 Notice, and in the Pentecostal age. Through the Lutheran age, through the Wesleyan age, it's been the same thing through this Pentecostal age. Now notice.

But at the opening of the Seven Seals, Revelation 10, the full Word is to be born into manifestation again, and vindicated by the Spirit of God, in the full strength as It was when He was here on earth; manifested in the same way, doing the same things that It did when It was here on earth. Amen! Hebrews 13:8, said, “Jesus Christ is the same yesterday, today, and forever.”

102 The world is in a Sodom condition. And the church has went into Sodom, with it, like Lot and his wife.

And I say that there is a Elected Church somewhere in this world, that's pulling out and set aside from those things, and the manifestation of God has attracted Its attention. We're at the last days.

103 The shuck has give forth its Strength into the Seed. It's went on out; it was a good shuck, but it served its time. See, it is the Word Bride of the Word Groom!

65-0218 - THE SEED IS NOT HEIR WITH THE SHUCK

104 The natural seed of Abraham, of Isaac, and Jacob, and...Or, natural seed, rather, of Ishmael, natural seed of Isaac, and so forth, had to go into the ground, in order to—to bring out this other, bring out Jesus.

And so has all these others, the seeds has to dry...I mean, the shucks has to dry, and the pollen has to dry, and everything dies, so the Seed can produce Itself. That's the way it's been in every age.

65-0218 - THE SEED IS NOT HEIR WITH THE SHUCK

99 She was not the Seed. Mary was not. Just a shuck, tassel, and stalk, carriers of part of the Word, not all the Word! Luther had justification; Wesley had sanctification; Pentecostals had the restoration of the gifts.

But when the Word come...Now, they could produce that, that, justification will save a man. You believe that? Sure, it was a carrier of the Word, just the same as I believe the stalk is part of the wheat. Sure, it is, but it's the carrier. It ain't the Life. he same yesterday, today, and forever.

Then along come sanctification. How many believes in sanctification? You believe the Bible, you have to. Sure. So still that's not; it's a little more like; that's two more words.

But then come the Pentecost, the restoration of the gifts. Speaking in tongues, they call it the initial evidence of the Holy Ghost. Speaking in tongues, there, they call that the initial evidence, which brought forth (the what?) the shuck, but they denominated.

But when you come to say, “I and My Father are One,” and these other things, then the shuck pulls away from It. But the real, genuine Bride Church will bring forth the entire Word of God, in Its fullness and in Its strength, for He’s the same yesterday, today, and forever.

THE WORD ITSELF BEING LIVED OUT
THROUGH HUMAN LIFE

63-0114 - A TRUMPET GIVES AN UNCERTAIN SOUND
93 Find in there, the Holy Spirit living
His Life in human beings, manifesting Himself
to the world. And it makes men thirst for Him:
unshakable, undisputable, the Word of God manifested
and showing Himself, the Word itself being lived out
through human life.

What a wonderful thing! There's nothing uncertain about that. You can see where God made a promise, and here it is being made manifest. Hundreds of years ago the prophets spoke of it, and here we see it coming to pass.

65-1205 - THINGS THAT ARE TO BE

31 You were all pre-planned by God. Nothing happens by chance, with God. He knows all about it. It's all pre-planned, planned for many generations back, so that you could be here tonight. Did you know that? [Congregation says, "Amen." —Ed.]

Just think, that, you, at one time...I'll repeat this again. You, at one time, was in your father, in the gene of your father. Now, he didn't know you at that time, neither did you know him at that time. But, you see, then you were put in the bedding ground, in the womb of mother, through holy wedlock. And then you become a person expressed in the image like your father, then there's fellowship.

65-1205 - THINGS THAT ARE TO BE

32 Now, the only way that you can be a son, a daughter of God, because you have to be the...have to have Eternal Life. And there's only one form of Eternal Life, and that's God's Life. Only one form of Eternal Life, that was God. There, to be a son of God, you had to be in Him always.

The gene of your Life, spiritual Life, tonight, was in God, the Father, before there was even a molecule. See? And you are nothing but the manifestation of the gene of Life that was in God, as a son of God.

Now you're expressed, after His Word has come in you, to Light up this age. You are expressing God's Life in you, because you are a son or a daughter of God. Therefore, you get what I mean? [Congregation says, "Amen." —Ed.] See? You are in... You are now made, you're setting in this church, tonight, because your duty is to express God to this nation and this people, and this neighborhood where you associate.

Wherever you are, God knew that you would be here, because you have to be one of His genes, or His attributes. You had to be. If you ever, if you've got Eternal Life, then It always was Eternal Life. And God, before there was a foundation, world, knew that you would be here. And when the Word, or the water, "the washing of the water of the Word" fell upon you—you, it was expressed in a being.

Now you have fellowship with your Father, God, just as you have with your earthly father. See? You are citizens of the King; not citizens, but you are children, sons and daughters of the living God, if it be that the Eternal Life dwells in you.

Now, then, if It was, Jesus was the fullness of God manifested. He was the fullness of the Godhead bodily. Therefore, when He came to the earth and was manifested in flesh, you were here in Him then, because He was the Word. “In the beginning was the Word; the Word was with God, and the Word was God. And the Word was made flesh, and dwelt among us.” The Word was made flesh. Therefore, you walked with Him, when you were in Him, when He was on earth.

You suffered with Him, and you died with Him. You was buried with Him. And now you are risen with Him, and manifested attributes of God, setting in Heavenly places; already raised, resurrected to new Life, and setting in Heavenly places in Christ Jesus. Oh, that means so much, nowadays, Church! That means so much to us, to see ourself positionally placed in Jesus Christ!

65-1205 - THINGS THAT ARE TO BE

33 Now, if we are those attributes of God, we cannot live by creeds. We cannot live by denominationalism. We must live by the Word, because the Bride is a part of the Bridegroom, like any wife is a part of her husband.

Therefore, we must be that Word Bride. And what is that Word Bride? The manifestation of this hour, the Bride, not a creed or a denomination; but a living oracle of God, a living attribute of God, displaying to the world the attributes of God, in the formation of the Bride that's to be expressed in this hour that we're now living.

62-0318 - THE SPOKEN WORD IS THE ORIGINAL SEED

175 When God and His Word becomes One (Hallelujah!), that...When God's Spirit waters the Seed of God, the Word of God, It produces God. And it's not the individual. It's God, for (what?) you are dead. You're not yourself no more. You reckon yourself dead, hollowed out, waiting for the Seed-Germ. Then what is it? It isn't you no more; isn't the man. It's God in the man. It's the Seed-Germ, like the beginning, spoken Word. It's God's Word made manifest in the man.

Then, it isn't the man; it's a man that's died. He can't be a hybrid and a son, at the same time. He's either a son of death or son of Life. So if he's the son of death, get it over to the devil and let him kill it... Give over to God, I meant, and let Him kill the devil that's in you, run him out, hollows you out. Then, let God plant His Own Life in you, then it's not you no more. It's God's Life, because it's God's Word watered by the Holy Spirit, will produce the same thing. You see it?

63-0803B - INVESTMENTS

162 The Bible said that God is in the Word. He is the Word. And if the Word in you, It produces God again. And He said, “The Word is a seed, and the seed produces what its kind is.” It’ll produce a godly life, a full consecrated life to Jesus Christ.

65-0919 – THIRST

63 Cause, Jesus said, “If we add one word to This, or take one Word from It, our part is taken out of the Book of Life.” See, not one Scripture. We must take It just the way It’s written. And God watches over His Word, to perform It, and we know that It’s got to be just right.

65-0919 – THIRST

64 So therefore, no matter what a church would say, what anyone else would say, if you're born of the Spirit of God, you become part of the Bible. God told Ezekiel, he, the prophet. He said, "Take the scroll and eat it," then the prophet and the scroll became part of each other.

And that's the believer when he receives the Holy Spirit; the Holy Spirit wrote the Bible, and the Spirit of God is the Word of God. "My Words are Spirit. In the beginning was the Word, and the Word was with God, and the Word was God.

And the Word was made flesh and dwelt among us.” Hebrews 13:8, “He is the same yesterday, today, and forever.” And when you are a part of that Word, oh, then let something come up contrary to that Word, [Brother Branham snaps his finger—Ed.] there is a little buzzer sets off right quick. See, It’s to warn you that death is in the road. We should never do that. There is also...

65-0221E - WHO IS THIS MELCHISEDEC?

53 Think of it! Before Jesus was ever born, four thousand years before He came on earth, and several thousand years before you come on earth, Jesus, in God's mind, died for the sins of the world, and the Book of Life was made, and your name was put on that Book of Life, before the foundation of the world. That's the Bible Truth. See, your name was ordained of God and placed on the Book of Life before the foundation of the world.

65-0221E - WHO IS THIS MELCHISEDEC?

54 You were there in His attributes. You don't remember it, no, because you're just a part of His Life. You are a part of God when you become a son or a daughter of God.

Just as you are a part of your earthly father! That's right. You are...The male carries the hemoglobin, the blood.

And when that has gone in—in the egg, then you become a part of your father; and your mother is a part of your father, also; so you're all a part of your father. Glory! That lets the denomination out, altogether. Uh-huh. Certainly does! God, in all, the only place!

65-0221E - WHO IS THIS MELCHISEDEC?

55 Notice now His attribute. Then the attribute was, first, God; the thought, the attribute itself, all in One, without being expressed. Then when He expressed, secondarily, He became then the Word. “And then the Word was made flesh and dwelt among us.”

62-1124B - INVESTMENTS

66....There's only one form of Eternal Life, and that's God. God is eternal. He never did begin, He never can end. And the only way we can be eternal with Him is to come part of Him. The only way I become a Branham was because I become part of a Branham.

Only way I become the human race is be one of them. And the only way that I can be a son of God is become part of God. Then I have to be borned of His Spirit. Amen. That's it. Sell all your denominational creeds and invest in Eternal Life.

62-0121E - THE MARRIAGE OF THE LAMB

100 So, you see, you can't be an artificial Christian. You can be an artificial, professed Christian.

101 But you can't be a Christian, become, until Christ injects Himself, by the baptism of the Holy Ghost, into you. Then you're connected with Him. You're no longer twain.

You are One. Christ promised to be in us, as the Father was in Christ. “I and My Father are One. You and I are One.” See? Christ in us! All that God was, He poured into Christ. And all that Christ was, He poured into the Church, to continue the work of the Gospel.

62-0121E - THE MARRIAGE OF THE LAMB

102 Then we become, not by artificial name, but by a reality of the Holy Spirit of Life connecting us into Christ. Then, through the power of His resurrection, we are raised from the dead things of the world, and setting with Him in Heavenly places. Amen. I like that.

Tonight, we're setting in Heavenly places in Christ Jesus, see, resurrected with Him; died to the things of the world, and took on Christ. And when we take on Christ, then the world is dead, then we no more care for the world. The world is dead to us. And we're...And it's dead to us, and we're dead to it.

62-0121E - THE MARRIAGE OF THE LAMB

103 You're a different person, different personality, because you are a new creation. Creation! Not the same creation, polished up; not a—a man that's turned a new leaf. But a man that's died, and been born again, and become a new creation in Christ Jesus, and the Spirit of the living God lives in the person.

104 Now, just like the woman that's no more Broy, she's a Branham, and she goes by that name.

105 And the Church is no more of the world, but it's in the Name of Christ, She is. She's connected with Him, by His Own Life.

WORD OF HIS WORD, SPIRIT OF HIS SPIRIT

63-0728 - CHRIST IS THE MYSTERY OF GOD REVEALED
593 Oh, if I could get the world to see that! Why? There
you are. There is the Body of Christ living, standing
redeemed. Redeemed! Oh, my!

63-0728 - CHRIST IS THE MYSTERY OF GOD REVEALED

594 Justified in His sight! Why are we justified? We are His victory. The Church is His victory. We come forth in this last days with this glorious Gospel, showing His victory. He died for this purpose, and we are proof of His victory. Amen! When we see Him coming down and living among the Church, that's His victory. Shows that he couldn't keep Him in the grave, neither can they keep us.

That's right. We're bound right. And we're already, potentially, arisen, because we've risen from dead, unbelief in His Word, from denomination creeds, to an Eternal Word of the Eternal God; which is Him, Himself, working through us, manifesting Himself that He is the same yesterday, today, and forever.

63-0728 - CHRIST IS THE MYSTERY OF GOD REVEALED
595 And then the Word moves on down into the Body,
from the Head. What is it? This same Word. Nothing can
be added or taken from It. So that same Word moves
from the Head, as the Day comes close, down into the
Body, down into the Body, vindicating that they are One.

They are Husband and Wife. They're flesh of His flesh,
Word of His Word; Life of His Life, Spirit of His Spirit.
See? Amen! How do you know it? Bears the same
record, same fruit, same Word. See? Manifests Christ;
same Life, same God, same Spirit, same Word, same
Book! Amen! Same signs, "Things that I do shall you
also." Oh, hallelujah! My!

62-0211 - ONENESS

30 Adam was a part of, or, Eve was a part of Adam, she was flesh of his flesh and bone of his bone. And that's what the correct union is. And that's what the correct union of the Church is, Spirit of His Spirit, Word of His Words. Never deviating from the Word, the real true believer will not compromise on any Word.

Remember, it was just one Word that Eve compromised on, one Word. But the true believer won't compromise on any Word. It'll hold the Sword of the Faith with...in faith, rather, the Sword of the Word, and claim every Divine promise God made. That's it.

62-0211 - ONENESS

31 They were God's examples to us, what we should be, them, ever present, never failing. When they spoke, God answered. He watched them, daily. Night, when they'd lay down to sleep, He watched over them. In the daytime, He guided them, fed them, loved them, communed with them constantly, all the time. They were in God's image, and God was in them. That's what makes a fellowship.

That's what makes the union, is God in His Church. That's the union. Much could be said, got many places to go. United with Him, is Eternal Life. And the only way we can unite with Him is to come every bit of His Word. That's right, take every promise and believe It.

62-0211 - ONENESS

32 Now, Eve was united until she broke one Word, or, doubted one Word being true. That separated her. Every Word, “Man shall not live by bread alone, but by every Word!” So we can be in God, united, because Adam and Eve, before the fall, afore the disbelieving of the Word, was an example of what we could be in Him. To be united with Him, is Life; to be separated from Him, is death. Now, if we follow His commandments!

62-0211 - ONENESS

33 We know we make mistakes, but you mustn't look at that. It's not your mistakes, because you're always going to have them. But, you see, it's following His Rules, following what He said do. Stumble and falling doesn't have one thing to do with It. A real true servant, if he'll stumble, he'll get up again. If he wobbles, God pulls him right back in the path, as long as he's in the path of duty.

But if he's off of the path of duty, God's not obligated to him. But as long as he's in the path of duty, God's obligated to him, knowing that he's just a man or a woman. He's obligated to that person as long as they're in the path of duty.

62-0211 - ONENESS

34 Now, the Church now is engaged to Christ for the wedding. The wedding has never been performed yet, it will be at the Wedding Supper of the Lamb. So, we see that the Church is now engaged, like a man engaged to his wife. What does he do while they're engaged? He's just bestowing all kinds of things, sending her presents, making her feel good.

Well, that's what Christ is doing to His Church. He's sending us gifts of the Spirit. How can you be engaged then when you're denying these gifts exist? It's the very love tokens. It's God's token to the Church. Jesus said so, "These signs shall follow them that believe."

62-0211 - ONENESS

35 Now, keep those things in mind. The Church must believe every Word, every promise, every iota, and claim It for themselves, and exercise themselves in It. If I was engaged to a girl, and I was a single man, and I'd send her something, an engagement ring, and she wouldn't wear it, then that shows she doesn't believe me. She—she—she doesn't want to be my bride.

And if Christ sends His church the gifts that He promised, and they refuse them and say “they’re not so,” they don’t want to be the Bride of Christ. They are espoused to some other lover, and not to Christ, the Bridegroom. So the real Church keeps the promise, and keeps all, and accepts the gifts that God sends them. All right.

**AND WE'RE LOOKING FOR
ANOTHER SON RISING**

55-0403 - FELLOWSHIP BY REDEMPTION

42 Now you pray this week that God will help us. And next Sunday morning, the Lord willing, at five to six o'clock, will be a sunrise service. Come out. And then we'll just stay at the hour. And as soon as the sun rises, we'll give God praise for what He did some two thousand years ago, rose up Jesus Christ at the rising of the sun.

And we're looking for another Son rising, the coming of the Lord Jesus, the second time, in glory.

65-0418M - IT IS THE RISING OF THE SUN

39 But, oh, it wasn't nothing, that sunrise, like the sunrise on that Easter morning. This time, with the sun leaping into the skies, it brought forth a greater sunrise than ever; because it came greater news with this sunrise, than it did with the sunrise at the beginning. This sunrise brought a news, that, "He is risen! He is quickened from the dead, as He's promised. He's risen from the dead."

65-0418M - IT IS THE RISING OF THE SUN

40 The first time the sun rose, in Genesis, it was bringing a message that there will be life upon the earth, mortal life.

41 But this time, when the sun rose, there was a—a dual sunrising; another, Son, rising. It was the...not only s-u-n rising, it was the S-o-n had risen to bring Eternal Life to all God's promised Seed that by foreknowledge He had seen laying upon the earth.

THE WORD LIVING AND IN ACTION

64-0705 - THE MASTERPIECE

159 Now, closing in a few minutes. I want you to notice real close of something that just happened.

Malachi 4 is to bring back, back to the original.

64-0705 - THE MASTERPIECE

160 She is smitten from the church, from the church body; smitten with Her Master, for the same purpose. She is the Word. Just the same as Joseph was smitten from his brethren, because he was the Word. And Jesus was smitten from His brethren, because He was the Word. The church is smitten...The Bride is smitten from the church, because She is the Word. There is your stages again; one, two, three, see, just exactly.

64-0705 - THE MASTERPIECE

161 The Word, living and in action, the Bible Bride, not some man-made bride; the Bible Bride, smitten and afflicted of God. “No beauty we should desire Her, but yet we did esteem Her smitten and afflicted of God.” That’s right.

She stands alone. She is smitten from all the denominations, according to Revelation 3. She is smitten out of the Laodicean Church Age that She was raised up in. See? This Church was raised up in the Laodicea Church Age; that's the husk. But if them others went...

SHE IS A PIECE OFF OF HER MASTER

64-0705 - THE MASTERPIECE

155 Notice, the Bride. If the Bride, in the beginning, was the Word, or the Bridegroom; and then if the Bride is taken from the Bridegroom, It must be the Word also. Notice, the Bride must be.

156 Why, why must the Bridegroom be the Word manifested, made plain? Is because the Bride and the Bridegroom are One. She is just a smitten piece off of Him. There is the Masterpiece. It was smitten. Say...

64-0705 - THE MASTERPIECE

157 Michelangelo could not reproduce that again. He could not put it back.

But God is going to do it. He is going to bring this little Bride, that's smitten, right back to the side of the original Word. And there He is, there is the Masterpiece, the family back again in garden of Eden.

64-0705 - THE MASTERPIECE

158 How is this Bride going to do this? How is this Wheat going to do this? Malachi 4 said, in the last days, it would be restored back, (what?) restored back like the beginning; take it back! “I will restore,” saith the Lord, “all the years the palmerworm, and cankerworm, and all these other things has eaten.

I will restore again.” Malachi 4 said, “He will restore the hearts of the people, and the Faith of the people, back to the original fathers again.” See? We see this right before us, Church. Where are we at?

64-0705 - THE MASTERPIECE

198 All others never appeared no more. They went out, never to come back again.

But the Bride came back, 'cause She was Alpha and Omega. God, the great Sculptor, has made Him a Masterpiece, for It is a piece of His first Masterpiece.

Like He made in the garden of Eden, and took a piece from, and made another piece and that was marred and fell, now He's been all this time building it up again. And He brought forth this Masterpiece, and was smitten, in order... That part that was smitten, was in order to bring back again that Masterpiece, again.

64-0705 - THE MASTERPIECE

199 So, the Masterpiece and the Son of God, the Masterpiece and the Bride, and It's a piece of Him, which must be the fulfilling of the Word. The Word has been fulfilled, and we're ready for the Coming of the Lord.

64-0705 - THE MASTERPIECE

200 O Church of the living God, bow your hearts and your—yourselves before God. These things are true. I know that it sounds like that, as such a great a thing as that would be, would be so spread out over the nations. It never was. He doesn't change His way. Just be thankful, Church, be thankful that you are where you are today if you're in Christ. Because, you see, now, and when that...

64-0705 - THE MASTERPIECE

201 Remember, all that Life will be gathered right into the Grain, for the resurrection, but the stalk must be burned. The rest of it; the husk and all, must be destroyed, and it will be. Don't trust in your, them denominations. You stay in the Word, the Life, God and His Masterpiece.